

2

1

PARTS LIST

ITEM	PART #	DESCRIPTION	NOTES
1	K1391	Series 4 SF Access Body	Assembly
2	1292	Insert Top / Bottom Cover	Top & Bottom
3	1696/1698	Insert End Cover/Ext. Insert End Cover	
4	1668	Insert Divider	
5	1689	Panel w/ Plastic Insert Adaptors	Panel by Other
6	1679	Panel w/ Aluminum Insert Adaptors	Panel by Other
7	1674/76/78	4", 6" or 8" Aluminum Insert Panels	
54	5168	Insert End Cover Screw	Drill #8 countersink

NOTE: PRE-CUT KITS ARE NOT PRE-DRILLED.

(Holes shown in this drawing are for reference only.
Drilling of pilot holes are to be done by fabricator.)

Ship To:
Sales Order #

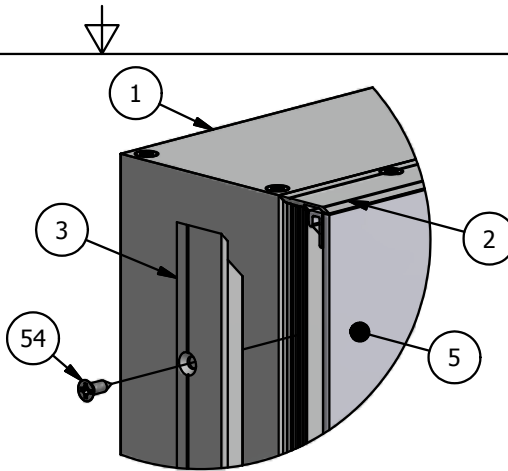
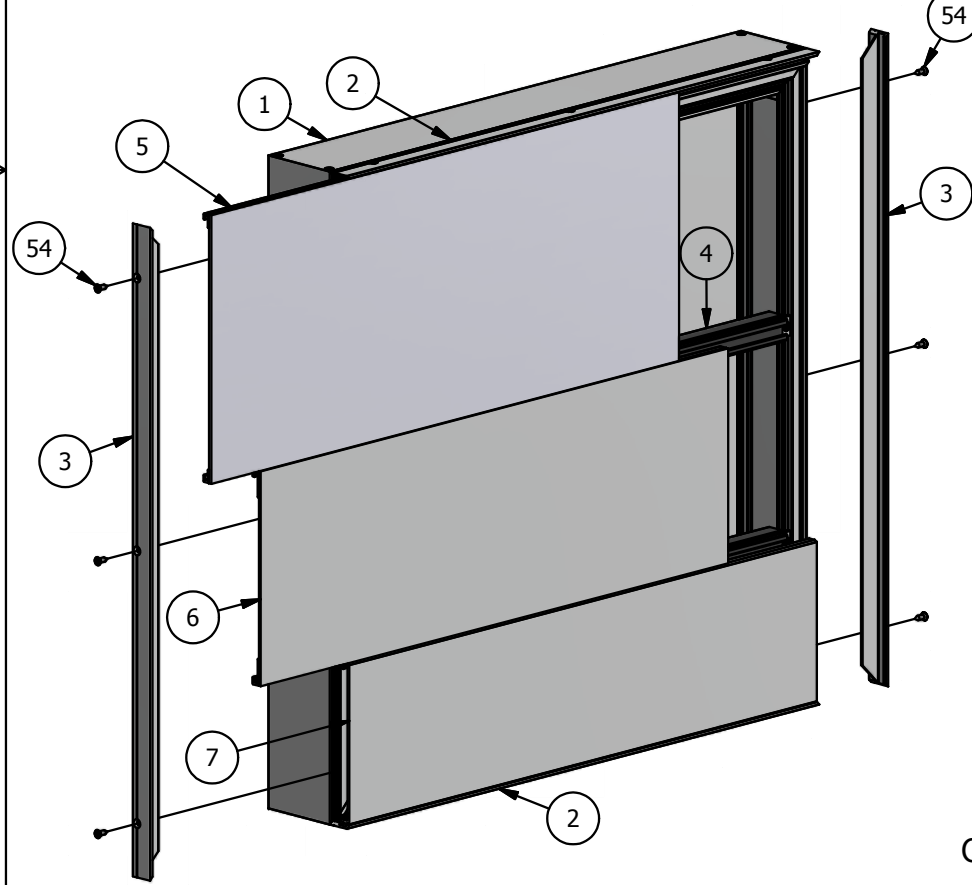

DETAIL A

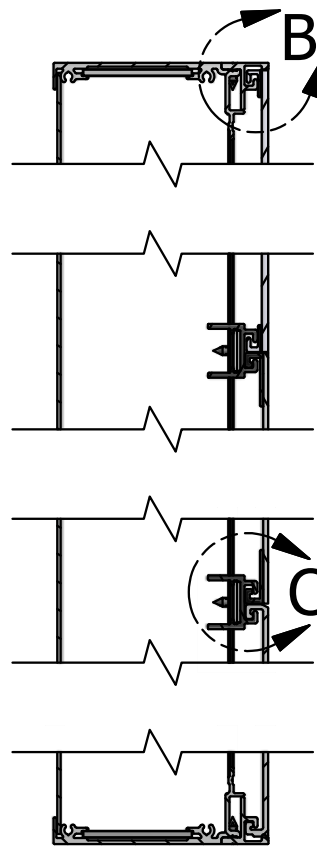
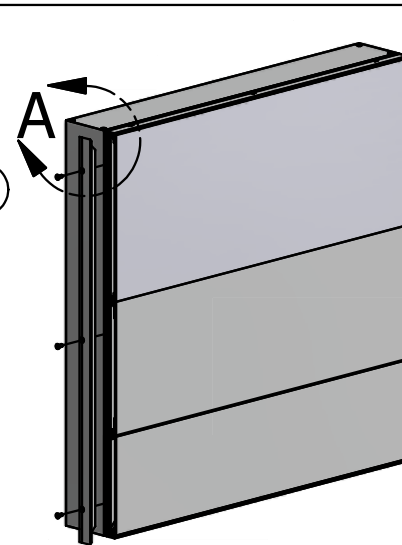

CABINET SECTION-VIEW
THRU HORIZONTALS

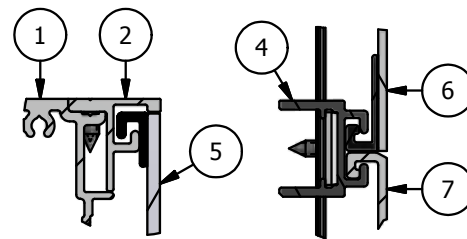

DETAIL B

DETAIL C

END COVER OPTIONS



Ext. End Cover
#1698

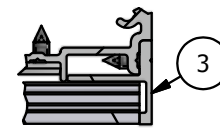

End Cover
#1696

THIS DRAWING WAS CREATED AT NO CHARGE TO ASSIST YOU IN VISUALIZING OUR PROPOSAL. THE DRAWING HEREIN IS THE PROPERTY OF SIGNCOMP. PERMISSION TO COPY OR REVISE THIS DRAWING OR TO USE THIS DRAWING FOR PRODUCTION IS STRICTLY PROHIBITED AND CAN ONLY BE COPIED, REVISED OR USED FOR PRODUCTION WITH THE EXPRESSED WRITTEN PERMISSION OF SIGNCOMP.

Project Name:	Series 4 SF Access Body w/ Insert Panels & End Cvr's - Assembly
Sign Company:	K1391/92/96
Revision:	
Date:	10/25/2017
Sheet:	1 of 1
Size:	A
Drawing By:	SBreihof

SignComp

B

B

A

A

2

1

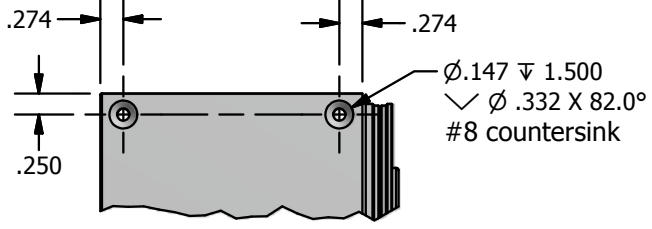

HOLE DETAIL
DRILLED BY OTHER

PARTS LIST			
ITEM	PART #	DESCRIPTION	NOTES
1	1391	Series 4 Single Face Access Body	Top & Bottom
2	1391	Series 4 Single Face Access Body	Sides
3	5340	Series 4 Access Body Corner Angle	One (1) per body corner
5		.063 Aluminum Back	By Other
60	5270	Access Body Corner Screw	See hole detail

NOTE: PRE-CUT KITS ARE NOT PRE-DRILLED.
(Holes shown in this drawing are for reference only.
Drilling of pilot holes are to be done by fabricator.)

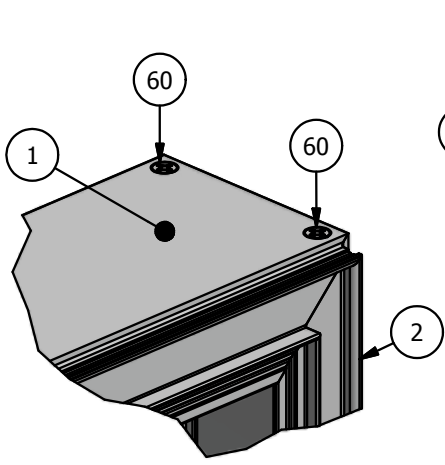
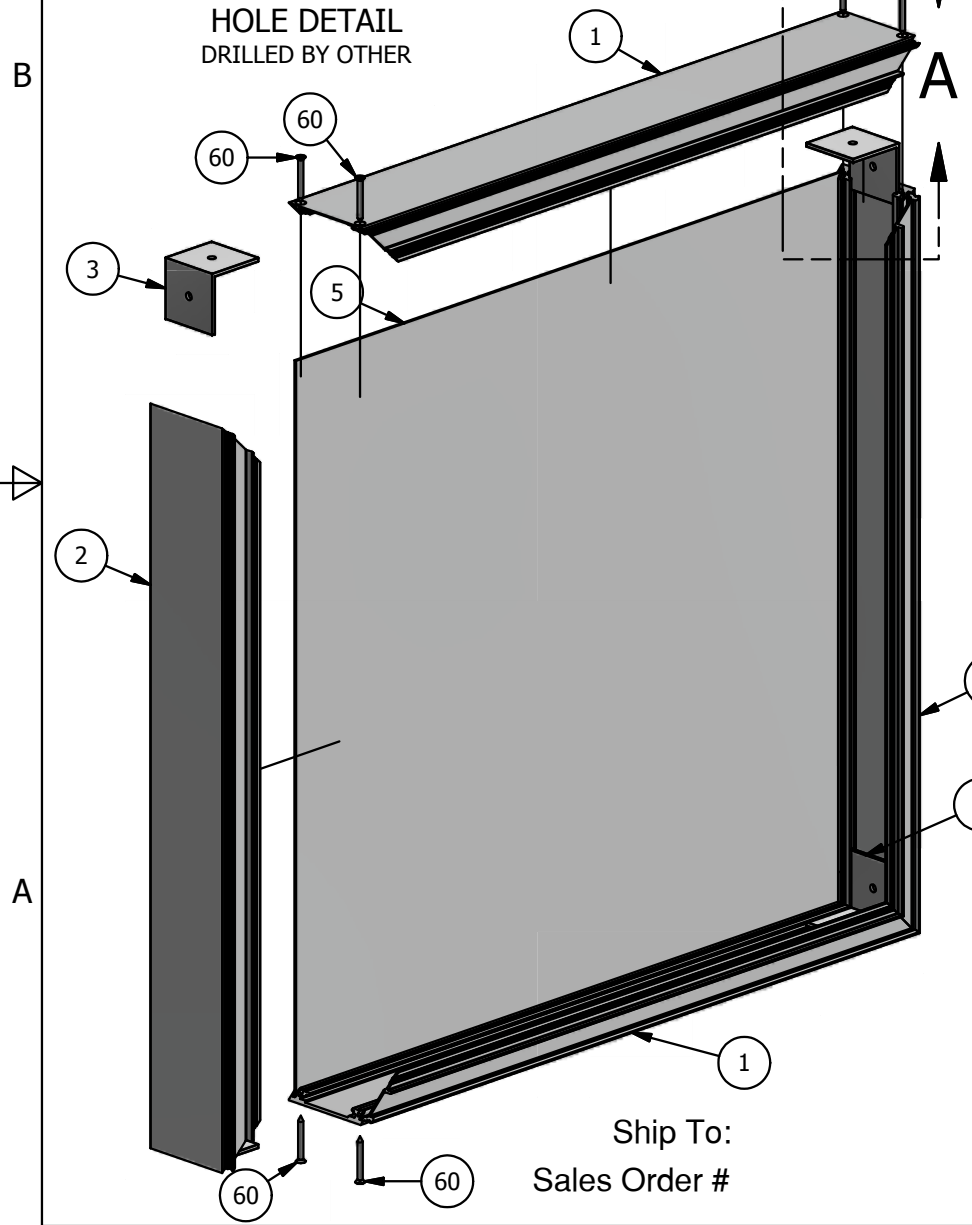

DETAIL A-2

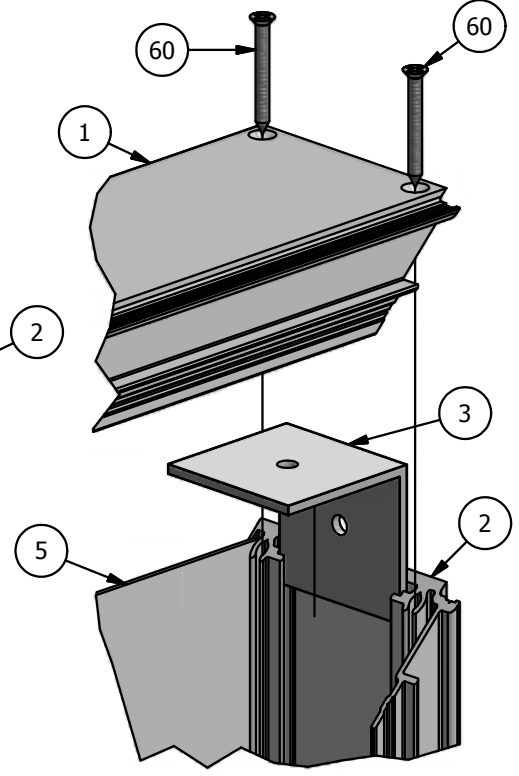

DETAIL A-1

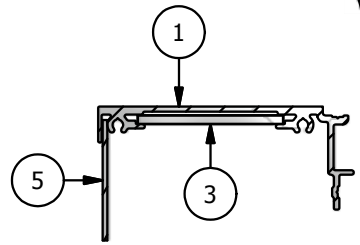

CABINET SECTION-VIEW

THIS DRAWING WAS CREATED AT NO CHARGE TO ASSIST YOU IN VISUALIZING OUR PROPOSAL. THE DRAWING HEREIN IS THE PROPERTY OF SIGNCOMP. PERMISSION TO COPY OR REVISE THIS DRAWING OR TO USE THIS DRAWING FOR PRODUCTION IS STRICTLY PROHIBITED AND CAN ONLY BE COPIED, REVISED OR USED FOR PRODUCTION WITH THE EXPRESSED WRITTEN PERMISSION OF SIGNCOMP.

Project Name: **Series 4 Single Face Access Body**
 Sign Company: **K1391**
 Revision: _____
 Date: **3/22/2017**
 Drawing By: **SBreihof**
 Sheet: **1 of 1**
 Size: _____



PARTS LIST			
ITEM	PART #	DESCRIPTION	NOTES
1	K1391	Series 4 SF Access Body	Assembly
2	1668	Insert Divider	
3	5306	Insert Divider Tab	Two (2) per divider
51	5168	Insert Divider Screw	Drill #8 1/8" hole

NOTE: PRE-CUT KITS ARE NOT PRE-DRILLED.
 (Holes shown in this drawing are for reference only.
 Drilling of pilot holes are to be done by fabricator.)

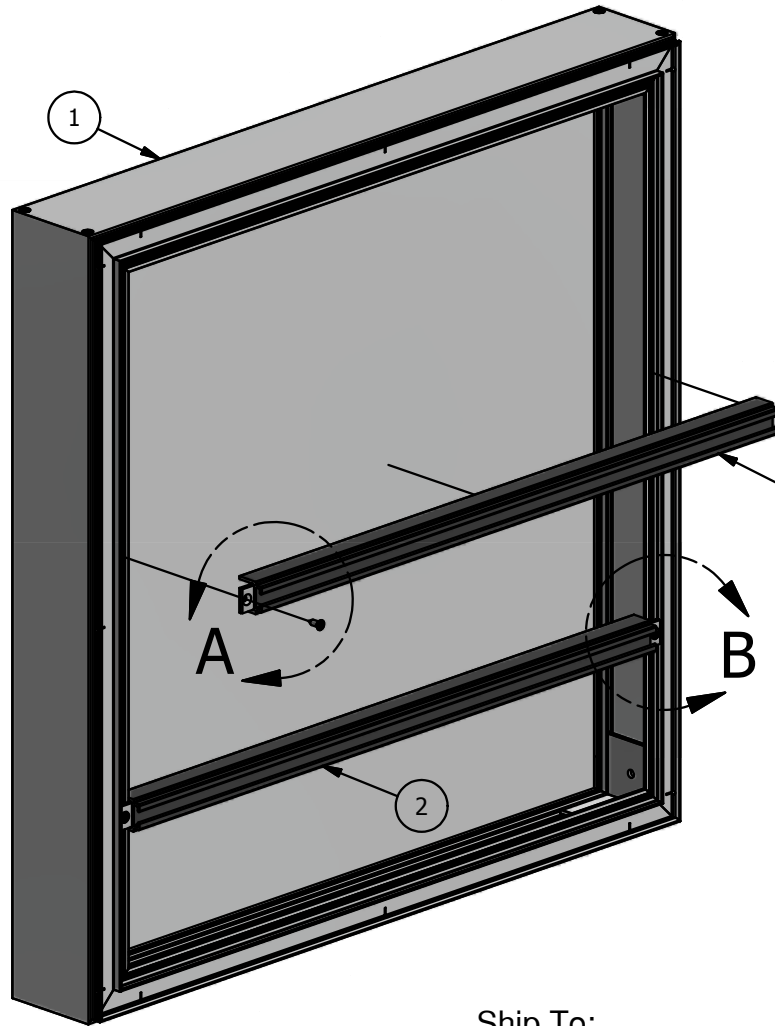

VERTICAL CROSS-SECTION VIEW

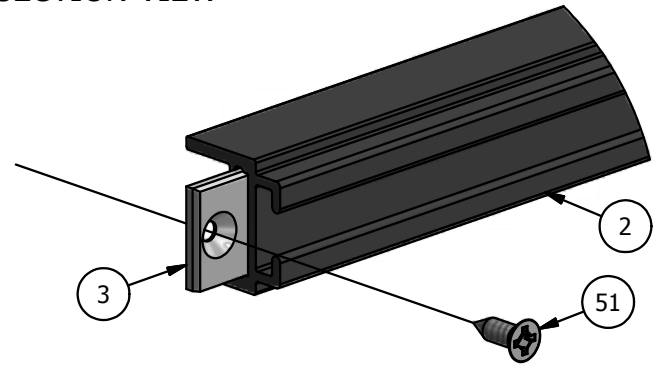
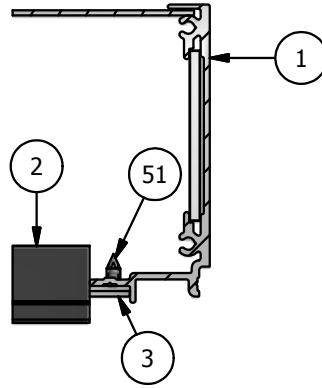

DETAIL A

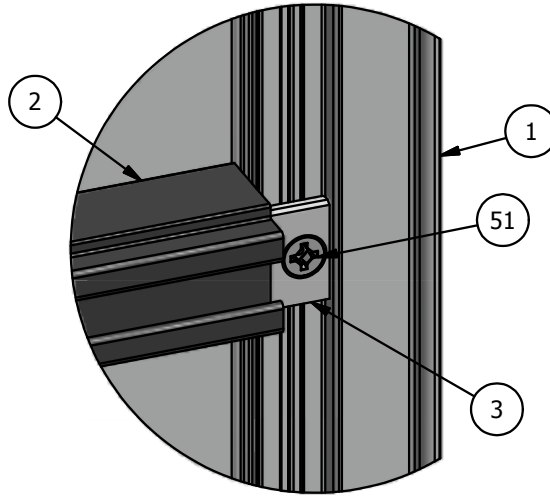

DETAIL B

Ship To:
Sales Order #

THIS DRAWING WAS CREATED AT NO CHARGE TO ASSIST YOU IN VISUALIZING OUR PROPOSAL. THE DRAWING HEREIN IS THE PROPERTY OF SIGNCOMP. PERMISSION TO COPY OR REVISE THIS DRAWING OR TO USE THIS DRAWING FOR PRODUCTION IS STRICTLY PROHIBITED AND CAN ONLY BE COPIED, REVISED OR USED FOR PRODUCTION WITH THE EXPRESSED WRITTEN PERMISSION OF SIGNCOMP.

Project Name:	Series 4 SF Access Body w/ Insert Divider - Assembly	Sheet:	1 of 1	Size:	A
Sign Company:	K1391/68	Date:	10/24/2017	Drawing By:	SBreihof
Part #:		Revision:			

SignComp

2



1

PARTS LIST

ITEM	PART #	DESCRIPTION	NOTES
1	K1391	Series 4 SF Access Body	Assembly
2	1292	Insert Cover	Top & Bottom
54	5168	Insert Top & Bottom Cover Screw	Drill #8 countersink

NOTE: PRE-CUT KITS ARE NOT PRE-DRILLED.

(Holes shown in this drawing are for reference only.
Drilling of pilot holes are to be done by fabricator.)

Ship To:
Sales Order #

B

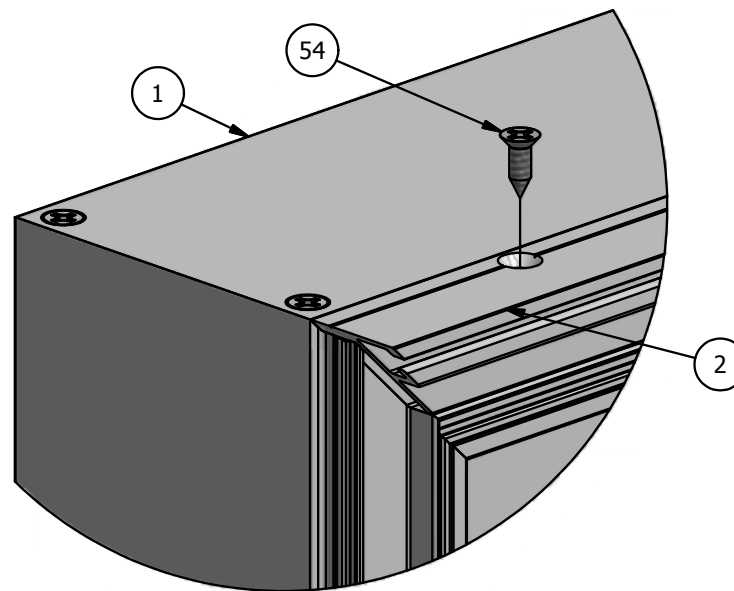
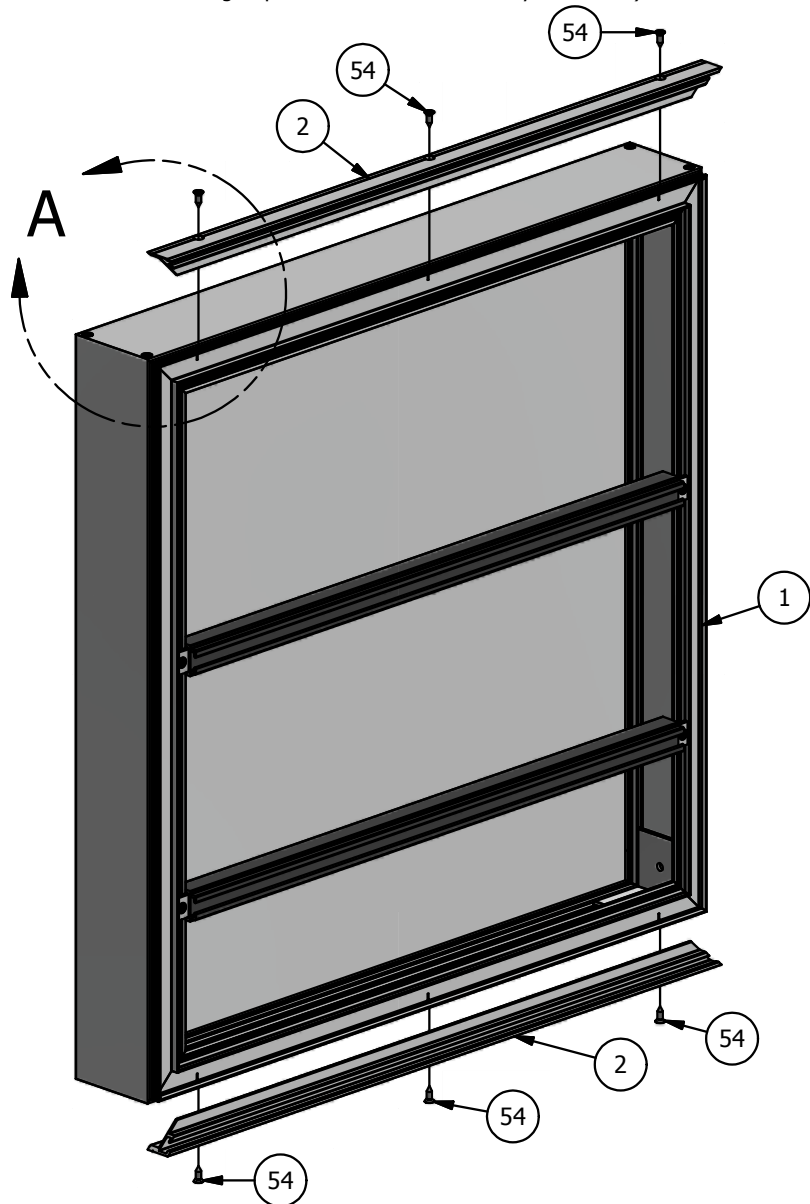

DETAIL A

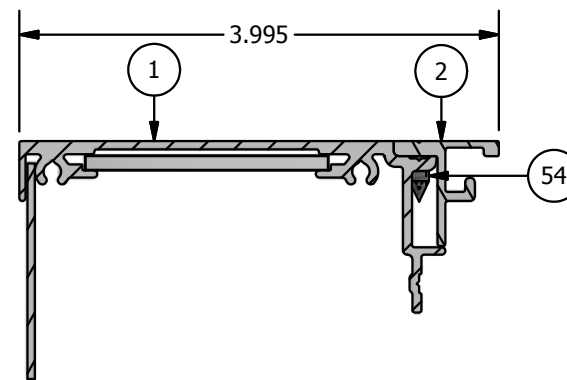

TOP CROSS-SECTION VIEW



A

2



1

THIS DRAWING WAS CREATED AT NO CHARGE TO ASSIST YOU IN VISUALIZING OUR PROPOSAL. THE DRAWING HEREIN IS THE PROPERTY OF SIGNCOMP. PERMISSION TO COPY OR REVISE THIS DRAWING OR TO USE THIS DRAWING FOR PRODUCTION IS STRICTLY PROHIBITED AND CAN ONLY BE COPIED, REVISED OR USED FOR PRODUCTION WITH THE EXPRESSED WRITTEN PERMISSION OF SIGNCOMP.

Project Name: Series 4 - SF Access Body w/ Insert Cover - Assembly

Sign Company: K1391/1292

Part #:

Revision:

Date: 10/25/2017

Drawing By: SBreihof

Sheet: 1 of 1

Size:

SignComp

B



A

PARTS LIST			
ITEM	PART #	DESCRIPTION	NOTES
1	Plastic Stock	.120 Acrylic Sheet	By Fabricator
2	Adhesive	Adhesive Tape (for Plastic) or Liquid Bonding Agent	By Fabricator
3	1689	Plastic Insert Adaptor	Attaches along the Top & Bottom on back side of panel

Ship To:
Sales Order#

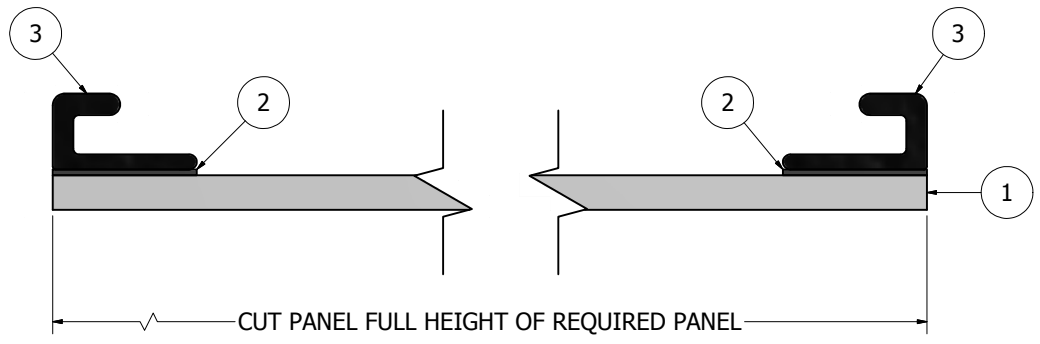
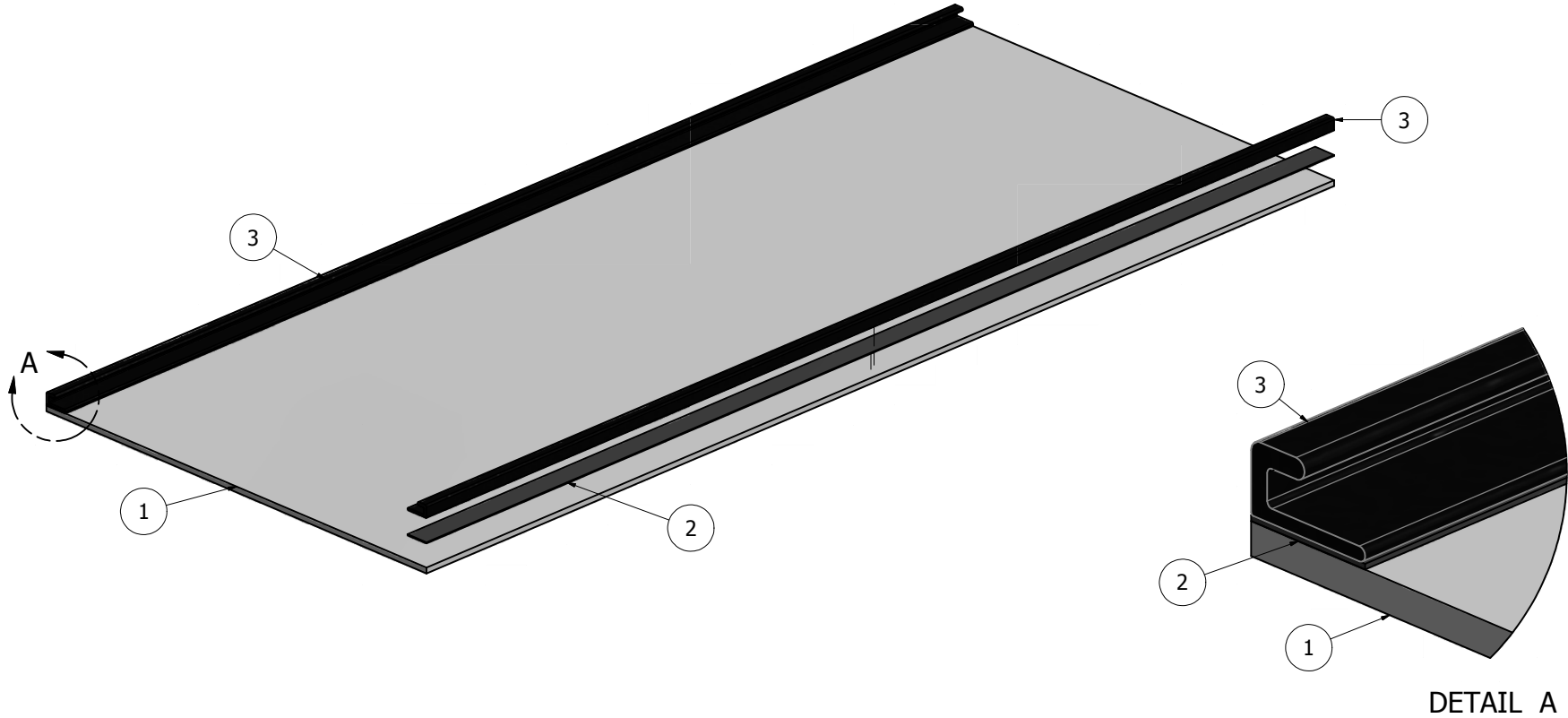

NOTE: PRE-CUT KITS ARE NOT PRE-DRILLED.
(Holes shown in this drawing are for reference only.
Drilling of pilot holes are to be done by fabricator.)

THIS DRAWING WAS CREATED AT NO CHARGE TO ASSIST YOU IN VISUALIZING OUR PROPOSAL. THE DRAWING HEREIN IS THE PROPERTY OF SIGNCOMP. PERMISSION TO COPY OR REVISE THIS DRAWING OR TO USE THIS DRAWING FOR PRODUCTION IS STRICTLY PROHIBITED AND CAN ONLY BE COPIED, REVISED OR USED FOR PRODUCTION WITH THE EXPRESSED WRITTEN PERMISSION OF SIGNCOMP.

DRAWING BY:	SBreihof	6/7/2013
Centroid X:	0.000 in	
Centroid Y:	0.000 in	
Principal Moments Ix:	0.000 in ⁴	
Principal Moments Iy:	0.000 in ⁴	
Section Modulus Ix:	0.000 in ³	
Section Modulus Iy:	0.000 in ³	

SignComp	
Plastic Insert Adaptor	
PART NO	REV
1689	
SHEET 1 OF 1	

PARTS LIST			
ITEM	PART #	DESCRIPTION	NOTES
1	Aluminum Stock	.090 Flat Aluminum Sheet	By Fabricator
2	Tape/Adhesive	Bonding Tape or Bonding Adhesive (for Aluminum)	By Fabricator
3	1679	Aluminum Insert Adaptor	Attaches along the Top & Bottom on back side of panel

Ship To:
Sales Order#

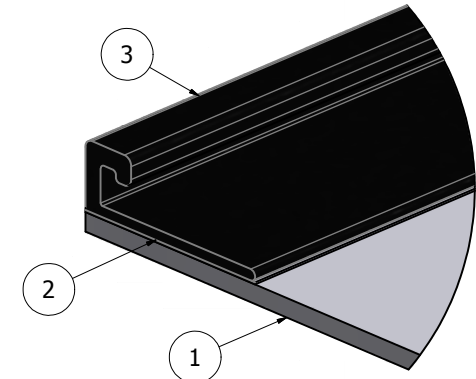
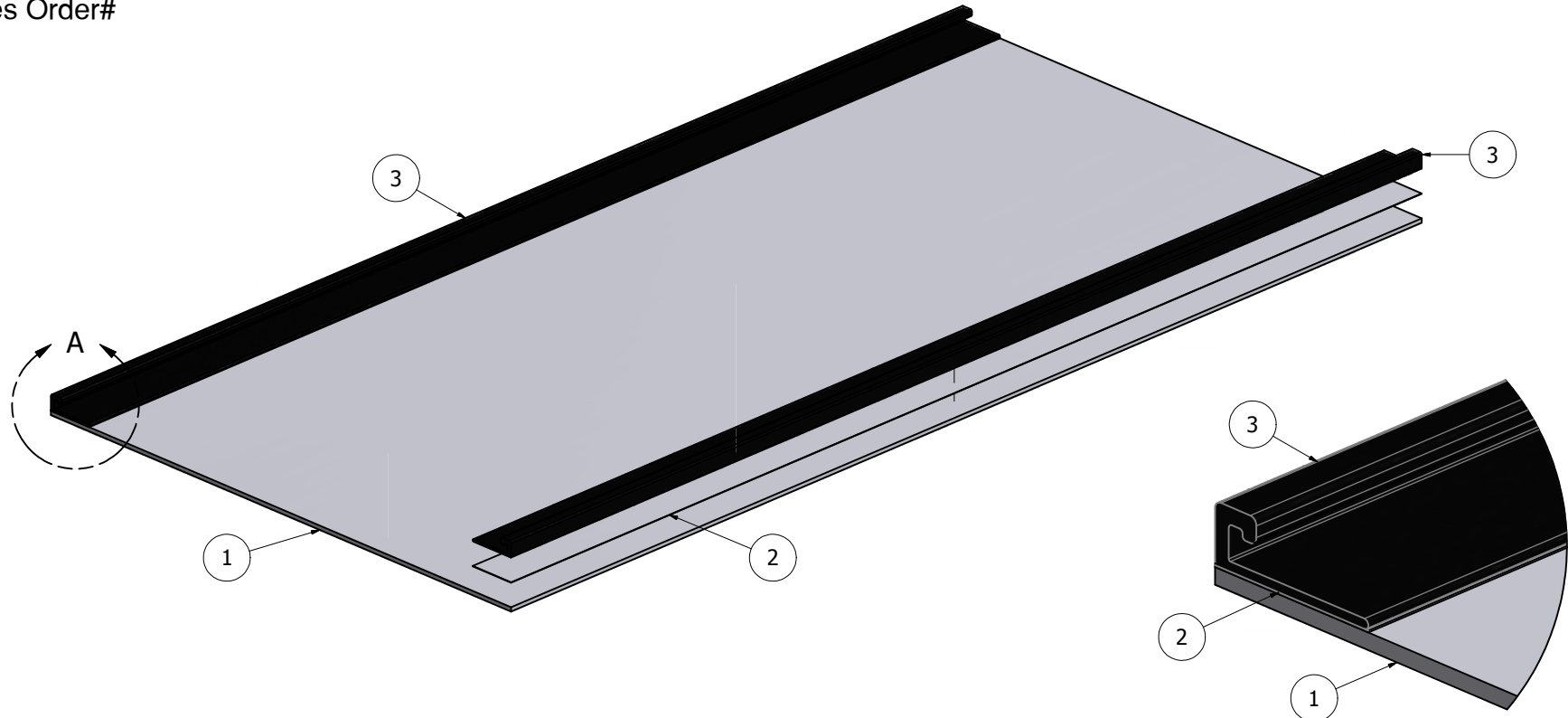

DETAIL A

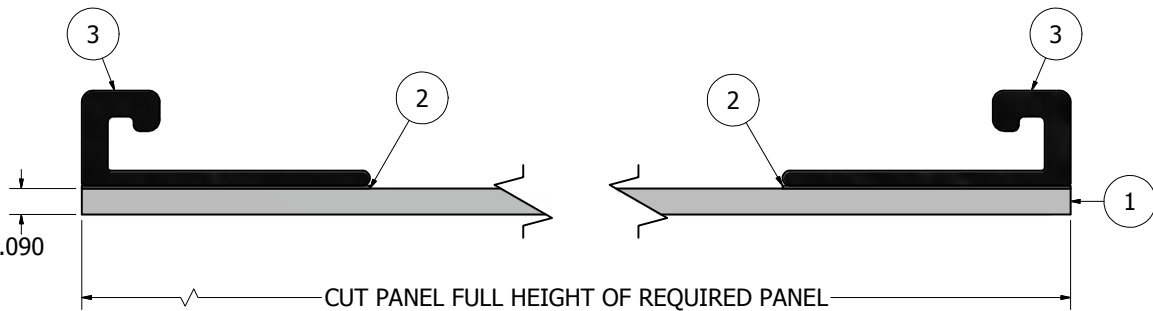

NOTE: PRE-CUT KITS ARE NOT PRE-DRILLED.
(Holes shown in this drawing are for reference only.
Drilling of pilot holes are to be done by fabricator.)

THIS DRAWING WAS CREATED AT NO CHARGE TO ASSIST YOU IN VISUALIZING OUR PROPOSAL. THE DRAWING HEREIN IS THE PROPERTY OF SIGNCOMP. PERMISSION TO COPY OR REVISE THIS DRAWING OR TO USE THIS DRAWING FOR PRODUCTION IS STRICTLY PROHIBITED AND CAN ONLY BE COPIED, REVISED OR USED FOR PRODUCTION WITH THE EXPRESSED WRITTEN PERMISSION OF SIGNCOMP.					
DRAWING BY:	SBreihof	6/7/2013			
Centroid X:	0.000 in				
Centroid Y:	0.000 in				
Principal Moments Ix:	0.000 in ⁴		Aluminum Insert Adaptor		
Principal Moments Iy:	0.000 in ⁴				
Section Modulus Ix:	0.000 in ³		PART NO	1679	REV
Section Modulus Iy:	0.000 in ³		SHEET 1 OF 1		